



OLC(T) 20

Fixed Gas Detector



Description

The OLC(T) 20 Series of gas detectors are designed for indoor or outdoor facility monitoring and other applications to accommodate your gas detection requirements at a reasonable price.

The stainless steel detector provides protection and resistance to corrosive agents. Classified IP 66, they are resistant to dust and water ingress. The precalibrated sensors of the OLCT 20 can be disconnected by turning the head of the unit.

These "smart" sensors can be calibrated on a work bench, outside hazardous areas.

OLC 20 Detector with a Wheatstone bridge output:

The generation of OLC 20 combustible sensors are unaffected by poisons. The units provide extremely quick response times and complete reliability.

OLCT 20 Transmitter with 4-20mA output:

The OLCT 20 sensor units, which are equipped with pre-calibrated sensors (flammable, toxic or oxygen), are classified as flameproof or intrinsically safety according to your needs or the gases detected. As in the case of the OLC 20, they are fitted on the housing by a M25 or 3/4" NPT thread.

Features

- Intrinsically Safe (IS) and XP approved
- Small in size
- Resistant to corrosion
- Pre-calibrated sensor unit

Applications

- Steel mills
- Petrochemical facilities
- Chemical industry
- Pharmaceutical industry
- Refrigeration industry
- Water treatment

OLC(T) 20

Fixed Gas Detection

Sensor Specifications

Gases	Type of sensor	Range (ppm)	Operating temperature *	Relative humidity uncondensed *
O ₂	electrochemical	0-30% vol	-20°C to +50°C	10% to 95% RH
CO	electrochemical	100, 300 and 1000	-20°C to +50°C	10% to 95% RH
H ₂ S	electrochemical	30, 100 and 1000	-20°C to +50°C	10% to 95% RH
NO	electrochemical	100, 300 and 1000	-20°C to +50°C	10% to 95% RH
NO ₂	electrochemical	10 and 30	-20°C to +50°C	10% to 95% RH
SO ₂	electrochemical	10, 30 and 100	-10°C to +50°C	10% to 95% RH
Cl ₂	electrochemical	10	-20°C to +50°C	10% to 95% RH
H ₂	electrochemical	2000	-20°C to +50°C	10% to 95% RH
HCl	electrochemical	30 and 100	-20°C to +40°C	10% to 95% RH
HCN	electrochemical	10 and 30	-20°C to +40°C	10% to 95% RH
HF	electrochemical	10	-10°C to +30°C	10% to 95% RH
NH ₃	electrochemical	100	-20°C to +40°C	10% to 95% RH
		1000		
		5000		
ETO / PO	electrochemical	30	-20°C to +50°C	10% to 95% RH
O ₃	electrochemical	1	-10°C to +40°C	10% to 95% RH
PH ₃	electrochemical	1	-20°C to +40°C	10% to 95% RH
ClO ₂	electrochemical	3	-20°C to +50°C	10% to 95% RH
SiH ₄	electrochemical	50	-20°C to +40°C	10% to 95% RH
COCl ₂	electrochemical	3	-10°C to +40°C	10% to 95% RH
AsH ₃	electrochemical	1	-10°C to +40°C	20% to 95% RH
CH ₄	catharometric	0-100 % vol	-20°C to +50°C	10% to 95% RH
H ₂	catharometric	0-100 % vol	-20°C to +50°C	10% to 95% RH
Flammable gas	catalytic	0-100 % LEL	-25°C to +70°C	10% to 95% RH

* Temperature at 20°C and at Atmospheric Pressure

Wiring connection depending on the type of area

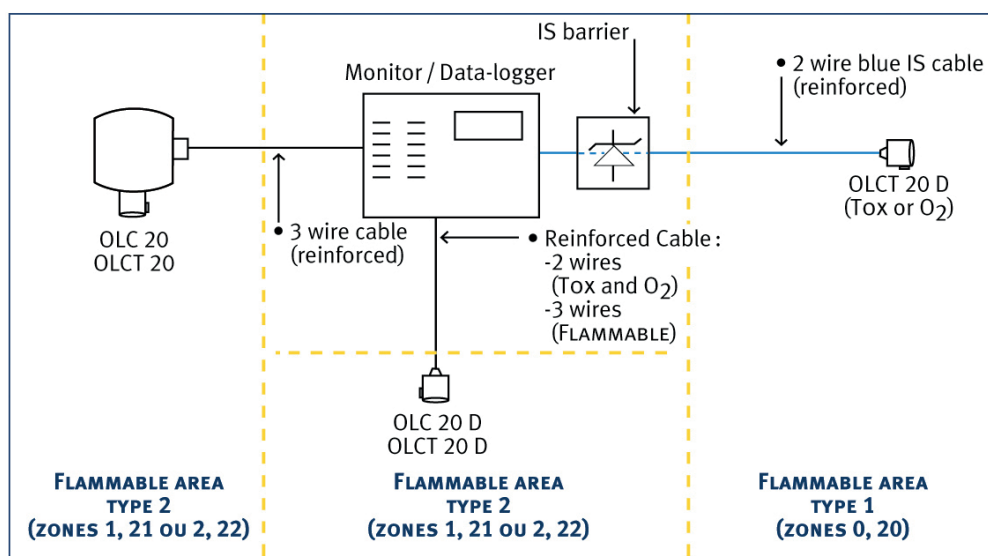

Pressure	Accuracy at full scale (at atmospheric pressure)	Life span (in month)	T (50)	IP	IS	XP
Atm +/- 10%	from 15 to 22% = 0,4% vol	30	6	66	YES	YES
Atm +/- 10%	+/- 2 ppm (range 0-100)	36	15	66	YES	YES
Atm +/- 10%	+/- 1,5 ppm (between 0-30 ppm)	36	15	66	YES	YES
Atm +/- 10%	+/- 2 ppm (range 0-100)	26	15	66	YES	YES
Atm +/- 10%	+/- 0,8 ppm	24	20	66	YES	NO
Atm +/- 10%	+/- 0,7 ppm range 0-10	36	15	66	YES	NO
Atm +/- 10%	+/- 0,5 ppm	24	50	66	YES	NO
Atm +/- 10%	+/-5 ppm range 0-100	24	50	66	YES	YES
Atm +/- 10%	+/- 0,5 ppm range 0-10	24	50	66	YES	NO
Atm +/- 10%	+/- 0,3 ppm range 0-10	24	40	66	YES	NO
Atm +/- 10%	+/- 0,5 ppm	24	50	66	YES	NO
Atm +/- 10%	+/- 10 ppm range 0-1000	24	20	66	YES	YES
Atm +/- 10%	+/- 150 ppm or 10%	24	60	66		
Atm +/- 10%	+/- 1 ppm	36	50	66	YES	NO
Atm +/- 10%	+/-0,05 ppm	12	50	66	YES	NO
Atm +/- 10%	+/- 0,05 ppm	18	40	66	YES	NO
Atm +/- 10%	+/- 0,3 ppm	18	50	66	YES	NO
Atm +/- 10%	+/- 1 ppm	12	40	66	YES	NO
Atm +/- 10%	+/- 0,05 ppm	12	50	66	YES	NO
Atm +/- 10%	+/- 0,05 ppm	18	40	66	YES	NO
Atm +/- 10%	1% vol	48	5	66	NO	YES
Atm +/- 10%	1% vol	48	5	66	NO	YES
Atm +/- 10%	1 % LEL between 0- 60 % LEL	48	6 (CH4)	66	NO	YES

Accessories

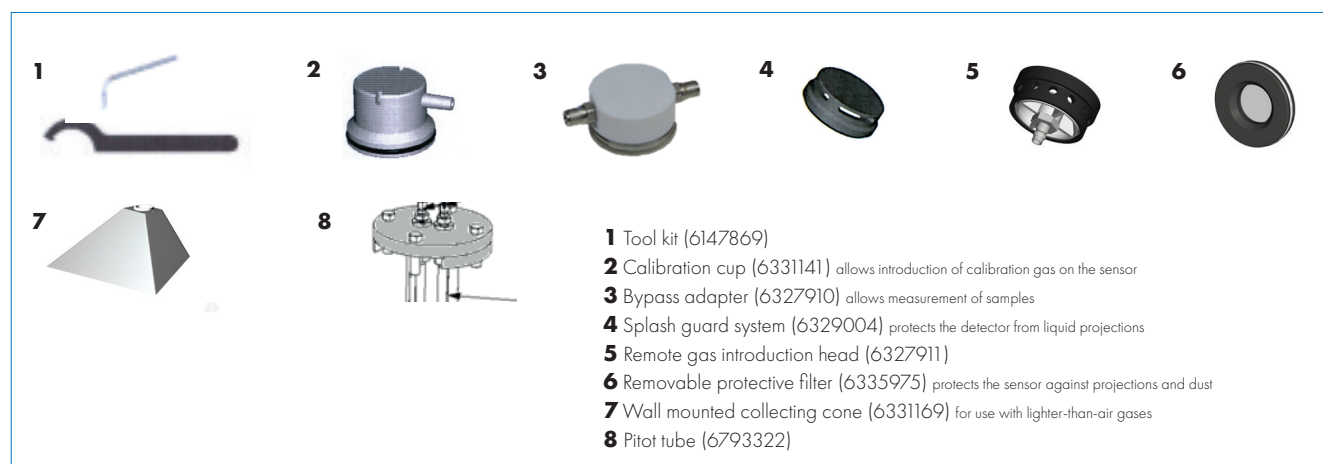

OLC(T) 20

Fixed Gas Detection

Specifications

	Detectors	OLCT 20	OLC 20
Type	XP transmitter	IS transmitter	XP detector
Gas detection principle	Catalytic/Electrochemical	Electrochemical	Catalytic
Detected gases	Flammable, toxics and oxygen	Toxics and oxygen	Flammable
Measuring range	see chart inside		
Sensor housing	Stainless steel type 316L		
Precalibrated sensor	yes	yes	no
Power supply at the detector	15 to 30 VDC (catalytic)	10 to 26 VDC	Depending on the detector
Maximum power consumption	100 mA (catalytic)	25mA	Depending on the detector
Output signal	4-20 mA	4-20 m A	Wheatstone bridge
Load impedance	250 Ω (catalytic) Depending on power supply (chemical)	47 Ω max	Not applicable
Wiring	3 reinforced wires (catalytic) 2 reinforced wires (chemical)	3 reinforced wires	3 reinforced wires
Loop impedance with Oldham monitor	32 Ω (catalytic) (1 km with 1.5 mm ²) 128 Ω (chemical) (4 km with 1.5 mm ²)	32 Ω (1 km with 1.5 mm ²)	32 Ω (catalytic) (1 km with 1.5 mm ²)
Wiring connection	delivered with a 6 mm-diameter cable		
Fastening	M25 thread to screw or 3/4" NPT		
Ingress protection	IP66	IP66	IP66
Certification	II 2 GD Ex d IIC T6 Gb INERIS 01 ATEX 0004X	II 1 GD Ex ia IIC T4 Ga Ex ia IIIC T135° C Da INERIS 01 ATEX 0004X	I m1 Ex ia I Ma INERIS 01 ATEX 0004X
CEM Mark	EN 50270	EN 50270	EN 50270
Weight	800 g	800 g	800 g
Dimensions	L 130 x D 60	L 130 x D 60	L 130 x D 60
Operating temperature (for electronic)	-25°C to +60°C	-25°C to +60°C	-25°C to +70°C

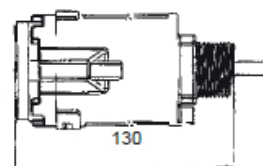

OLDHAM SIMTRONICS quality assurance programmes demand the continuous assessment and improvement of all OLDHAM SIMTRONICS products. Information in this leaflet could thus change without notification and does not constitute a product specification. Please contact OLDHAM SIMTRONICS or their representative if you require more details.



AMERICAS
4055 Technology Forest Blvd.
The Woodlands,
TX 77381, USA
Tel.: +1-713-559-9200
Fax: +1-713-893-6729

EMEA
ZI Est, Rue Orfla,
CS 20417
62027 ARRAS CEDEX, France
Tel.: +33-3-21-60-80-80
Fax.: +33-3-21-60-80-00

ASIA PACIFIC
290 Guiqiao Road
Pudong, Shanghai 201206
People's Republic of China
Tel.: +86-21-3127-6373
Fax: +86-21-3127-6365